



AP Dynamometer Specifications

Pound Capacities

5" (125mm) Dial Size		10" (250 mm) Dial Size		Ultimate Safety Factor	
Part number	Cap x division size	Part number	Cap x division size		
LOW	30006-0019	500 x 5	30007-0018	500 x 2	5:1
	30006-0027	1,000 x 10	30007-0026	1,000 x 5	5:1
	30006-0035	2,000 x 20	30007-0034	2,000 x 10	5:1
	30006-0043	4,000 x 25	30007-0042	4,000 x 20	5:1
	30006-0050	5,000 x 50	30007-0059	5,000 x 20	5:1
	30006-0068	6,000 x 50	30007-0067	6,000 x 25	5:1
	30006-0076	8,000 x 50	30007-0075	8,000 x 50	5:1
	30006-0084	10,000 x 100	30007-0083	10,000 x 50	5:1
MED	30006-0092	15,000 x 100	30007-0091	15,000 x 100	5:1
	30006-0100	20,000 x 200	30007-0109	20,000 x 100	4.5:1
HIGH			30784-0017	30,000 x 200	5:1
			30784-0025	40,000 x 200	4:1
			30784-0033	50,000 x 200	3:1
			30332-0014	100,000 x 500	4:1

Kilogram Capacities

5" (125mm) Dial size		10" (250mm) Dial size		Ultimate Safety Factor	
Part number	Cap x division size	Part number	Cap x division size		
LOW	30006-0142	200 x 2	30007-0141	200 x 1	5:1
	30006-0134	500 x 5	30007-0133	500 x 2	5:1
	30006-0159	1,000 x 10	30007-0158	1,000 x 5	5:1
	30006-0126	2,000 x 20	30007-0125	2,000 x 10	5:1
	30006-0167	4,000 x 25	30007-0166	4,000 x 20	5:1
	30006-0175	5,000 x 50	30007-0174	5,000 x 20	5:1
	MED	30006-0118	10,000 x 100	30007-0117	10,000 x 50
HIGH			30784-0041	15,000 x 100	5:1
			30784-0058	20,000 x 100	4:1
			30332-0022	50,000 x 200	4:1

Model AP Dynamometer Dimensions

Dimensions in inches (mm)
 Drawing scales differ between capacities
 Dimensions subject to manufacturer /supplier tolerances and
 are subject to change without notice.

Low & Medium Capacities 500-20,000lb / 200-10000kg

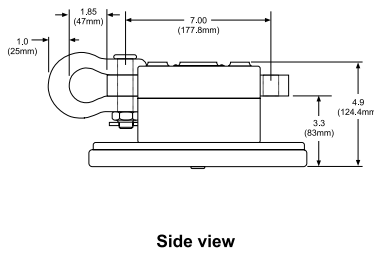
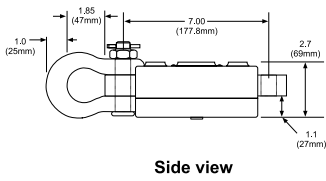
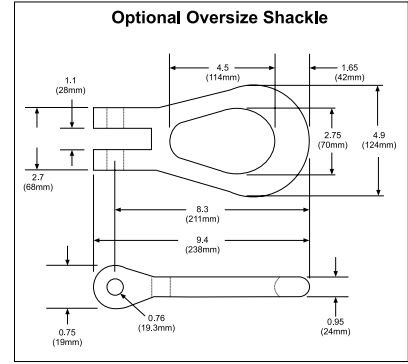
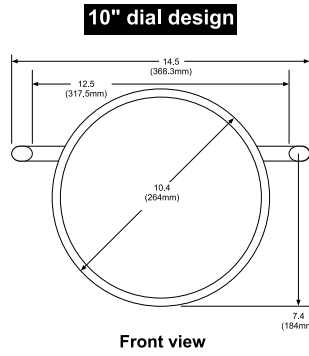
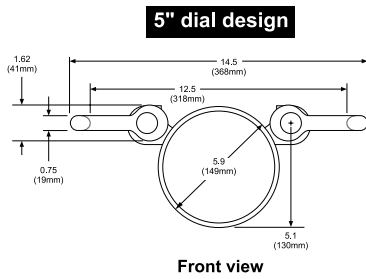

High Capacities 30,000-50,000lb / 150000-20000kg

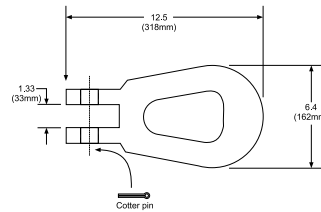
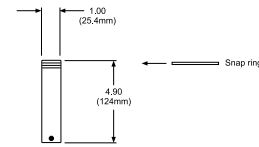
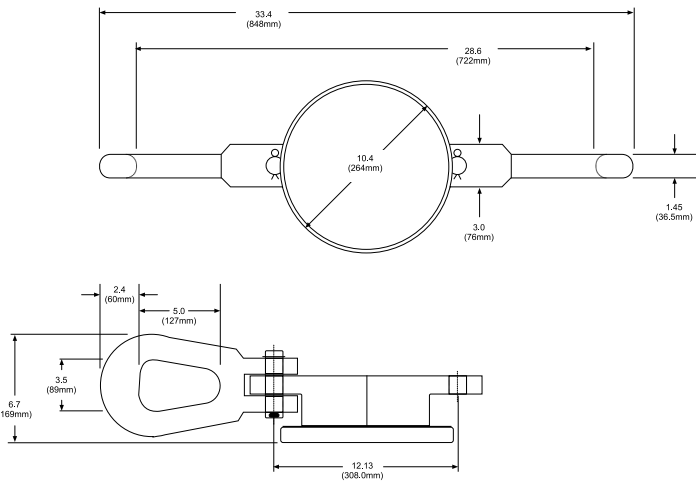

High Capacities 100,000lb / 50000kg

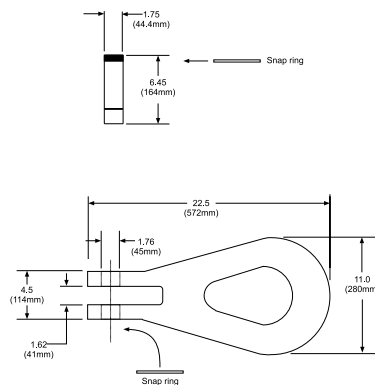
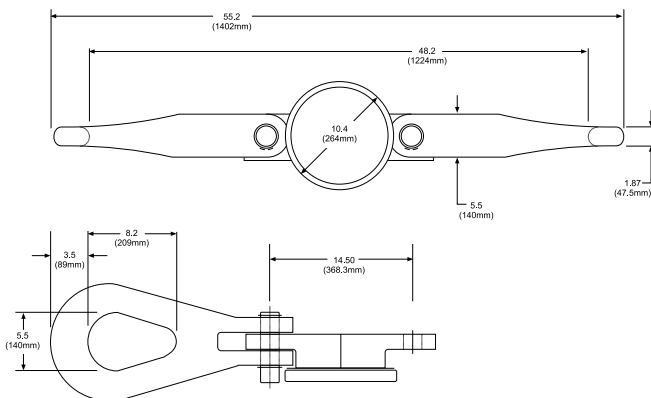

Model AP Mechanical Dynamometer Specifications

Accuracy: + 0.5% of capacity

Temperature range: -50° to 140° F (-45° to 60° C)

Ultimate Safety Factor:

See table on cover for minimum USF

Construction:

Pressure bar—

Aircraft quality E4340 steel or 7075-T651 aluminum

Shackles –

A4140 forged steel (machined from E4340 steel)

Shackle pins –

Machined from E4340 steel

Case housing:

5" models are equipped with high strength composite plastic case.

10" models use cast aluminum enclosure.

Corrosion protection: Pressure bar protected with durable powder coat paint. Shackles and pins are electroless nickel plated. All integral machining and fasteners are produced from noncorrosive materials or have suitable plating.

Zero control: Zero up to 20% of capacity. Zeroed load must be considered as part of ultimate load.

Calibration: Traceable to NIST.

Documentation: Includes User's Guide and signed calibration card.

Carry case/crate:

Low/Med capacity 5" dial – includes plastic carry case

Low/Med capacity 10" dial – optional steel carry case

All high capacity – includes reinforced plywood crate

Periodic proof loads: Controlled 150% proof loads permitted annually.

Shipping and packing (approximate weights):

5" Low and Med capacities

Net weight	9 lb
Shipping weight	15 lb
Shipping box	16" x 11" x 7"

10" Low and Med capacities

Net weight	16 lb
Shipping weight	26 lb
Shipping box	14" x 14" x 7"

30,000 – 50,000 lb (15000 – 20000 kg) High capacity

Net weight	64 lb
Shipping weight	98 lb
Shipping crate	37.5" x 13" x 10.5"

100,000 lb (50000 kg) High capacity

Net weight	226 lb
Shipping weight	315 lb
Shipping crates	22.5" x 12.5" x 8" 26" x 13" x 9" (2 included)



For More Information, Contact:



Data Weighing Systems, Inc.

2100 Landmeier Rd • Elk Grove IL. 60007

Phone 800-397-6301 • Fax 847-437-2920

www.dataweigh.com • sales@dataweigh.com